

EH Micro series **025/035/035V**

EH Micro Series

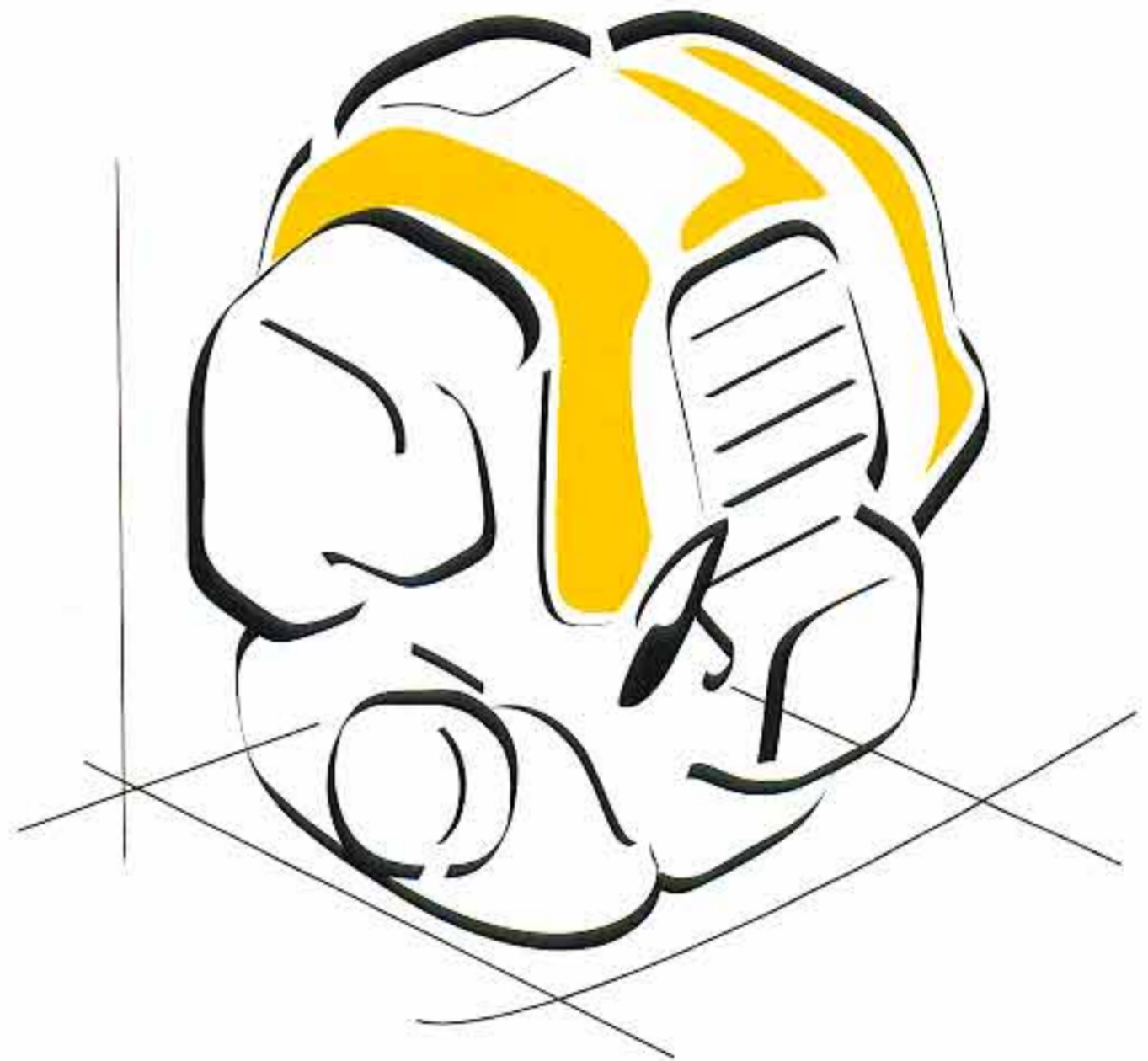

Robin
SUBARU
MFD. BY FUJI HEAVY INDUSTRIES LTD.,
TOKYO JAPAN

Air cooled 4 cycle

OHV Gasoline Engine

EH Micro series Advanced Micro 4-cycle OHV Design

■ Multi-Position Operation

Robin unique lubrication system, which has a separate oil chamber, allows engine to be operated in any position.

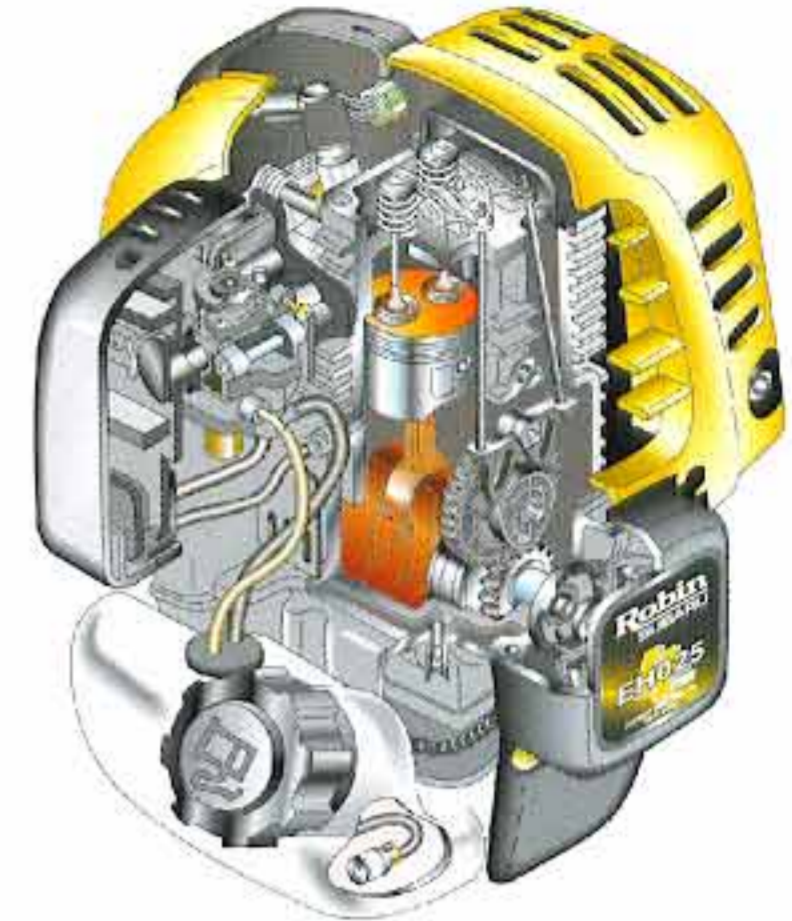
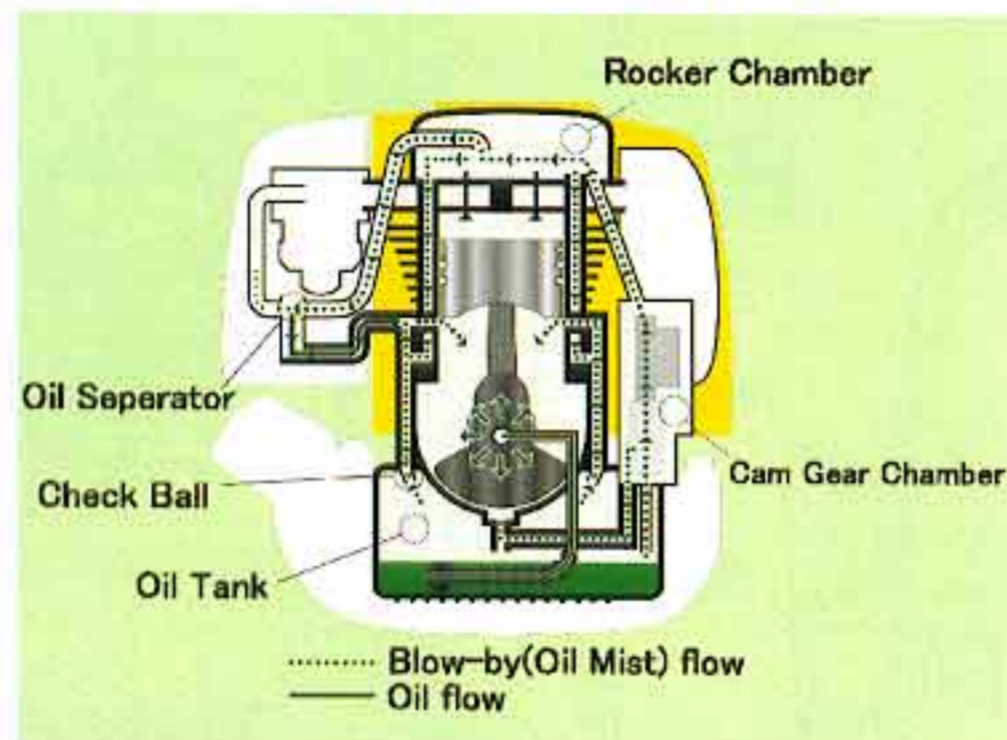

■ Lightweight and Compact

Robin advanced technology offers both EH025 and EH035 as the lightest and most compact 4-cycle engines in the same class.

■ Environmentally Friendly

● Clean Exhaust Emission

Both EH025 and EH035 comply with EPA Phase 2 and CARB Tier II in the USA. The emission is about one tenth of the same size 2-cycle engine.

● Quiet and Low Vibration

The Micro 4-cycle OHV design greatly reduces noise and delivers smooth power with soft tone. The well-balanced design reduces vibration to remove operator's fatigue.

■ Fuel-efficient and Lower Oil Consumption

40% lower fuel consumption than the same size 2-cycle engine as well as 1 to 2 cc oil consumption. (3 to 4 cc when the engine is green.)

■ Powerful and Responsive

The Micro 4-cycle OHV design delivers high torque and horsepower. Quick throttle response and wide RPM range meet requirements of demanding applications.

■ Easy operation

● Easy Starting

Employment of automatic decompression system provides easy pull and reliable starting.

● Easy and Convenient on Fuel-Handling

No need to use Fuel-oil mix. You can use automotive unleaded gasoline. This also gives less smoke and smell as compared to 2-cycle engine.

■ Durable and Reliable

Robin traditional design concept "Durability and Reliability" is achieved by:

- Heavy duty crankcase with hard chromium plated cylinder
- Powder metal inserted cam gear
- Special steel connecting rod with needle bearings to both ends
- Sponge element over full surface (standard) and additional felt element (optional)
- Durable and heat resistance oil seal with fluorine

■ Special Feature for EH025P/035P

Additional ball bearing at the outer flange for reliable operation

■ Special Features for EH035V

Oil inlet and oil drain plug are exclusively designed for vertical-shaft engine. This realizes extremely easy oil pouring and draining works.

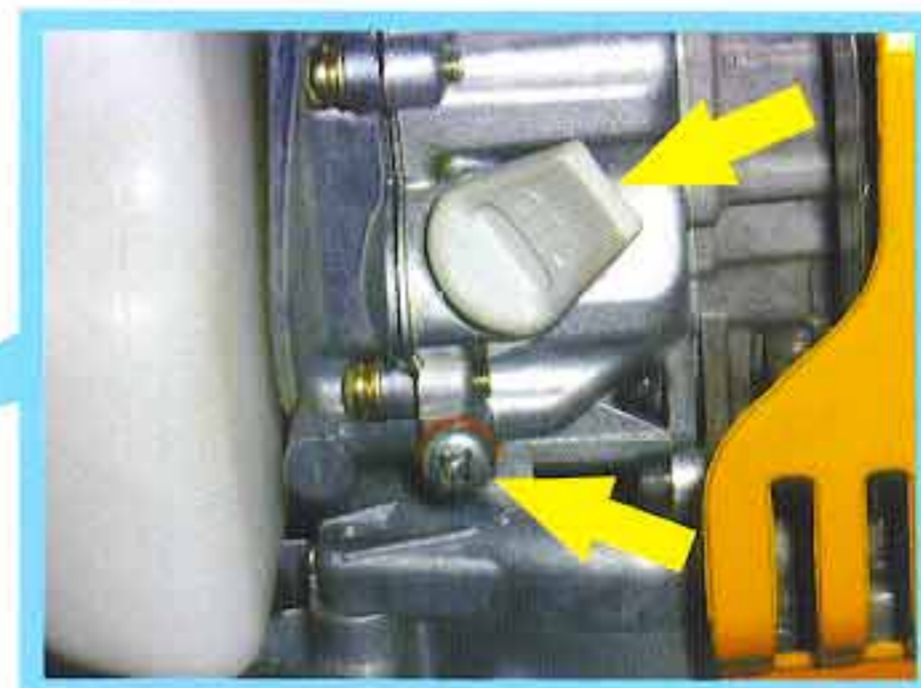

SPECIFICATIONS

Model		EH025A	EH025P	EH035A	EH035V
Type		Air-cooled, 4-cycle, OHV gasoline engine			
Bore x Stroke	mm (in.)	34 x 27 (1.34 x 1.06)		39 x 28(1.54 x 1.10)	
Piston displacement	cc (cu.in.)	24.5 (1.49)		33.5 (2.04)	
Continuous output	kW [PS] (HP)/rpm	0.55 [0.75] (0.75) / 7000		0.81 [1.10] (1.10) / 7000	
Maximum output	kW [PS] (HP)/rpm	0.81 [1.1] (1.1) / 7000		1.18 [1.60] (1.60) / 7000	
Maximum torque	N·m [kgf·m]/rpm (lbf·ft/rpm)	1.18 [0.12] / 5000, (0.87 / 5000)		1.76 [0.18]/5000, (1.30 / 5000)	
Direction of rotation		Counter clockwise as viewed from P.T.O. shaft side			
Fuel		Automotive unleaded gasoline			
Fuel tank capacity	liters (U.S. gal.)	0.5 (0.13)		0.65 (0.17)	
Lubricant		Engine oil SAE 10W-30 SF or higher			
Lubrication		Forced lubrication			
Lubricating oil capacity	liters (U.S. gal.)	0.08 (0.021)		0.1 (0.026)	
Carburetor		Diaphragm type			
Starter		Recoil starter			
Ignition system		Transistorized magneto			
Spark plug		NGK CMR6A (M10 x P1.0)			
Air cleaner		Semi-wet type			
Dry weight	kg (lb)	2.8 (6.17)	3.0 (6.61)	3.5 (7.72)	
Dimension length x width x height	mm (in.)	170 x 213 x 225 (6.69 x 8.39 x 8.86)	219 x 213 x 225 (8.62 x 8.39 x 8.86)	191 x 234 x 246 (7.52 x 9.21 x 9.69)	191 x 220 x 261 (7.52 x 8.66 x 10.28)

OPTIONS

- Spark arrester
- Engine Stop switch
- Stand (EH025 only)
- Fuel tank guard
- Dual element air cleaner
(EH035 only)
- Powder Metal (Steel) Clutch



 **SUBARU**
FUJI HEAVY INDUSTRIES LTD.
INDUSTRIAL PRODUCTS COMPANY
 4-410 ASAHI, KITAMOTO-SHI, SAITAMA, 364-8511, JAPAN
 TEL:+81-48-593-7798, FAX:+81-48-593-7946
<http://www.fhi.co.jp/robin/>



ISSUE EMD-EL0121
 Printed in Japan 2004. 01 ©.Y

Specifications are subject to change without notice.

EH025

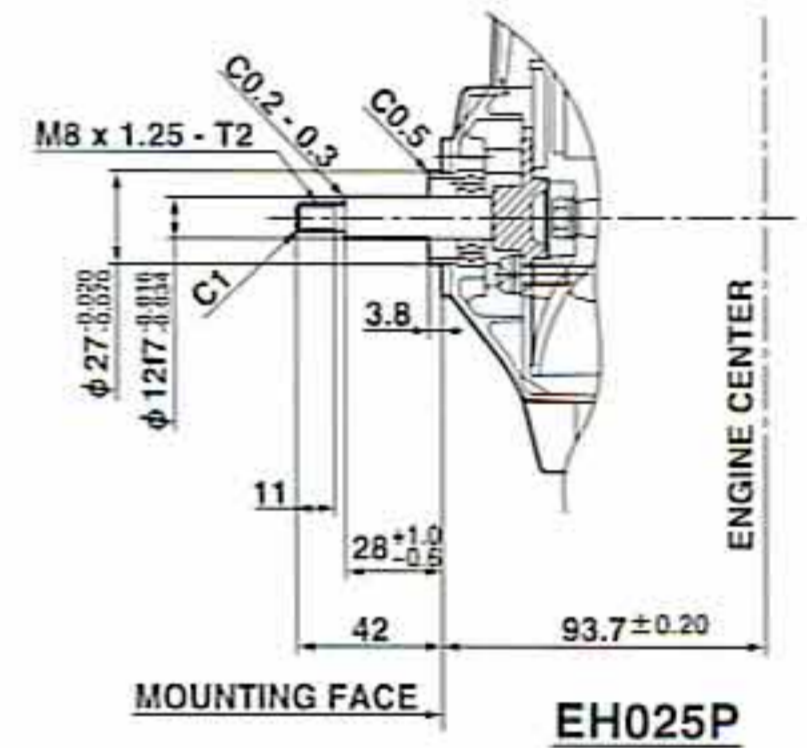
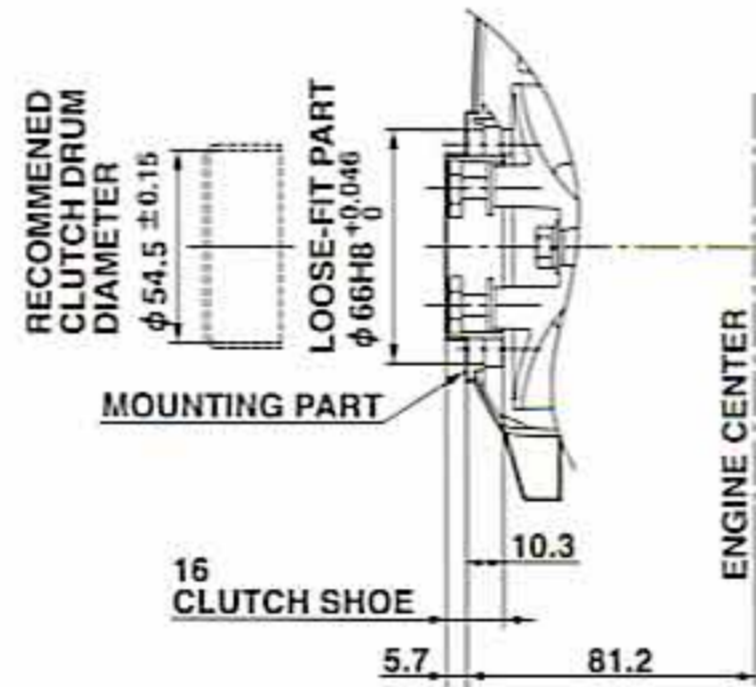
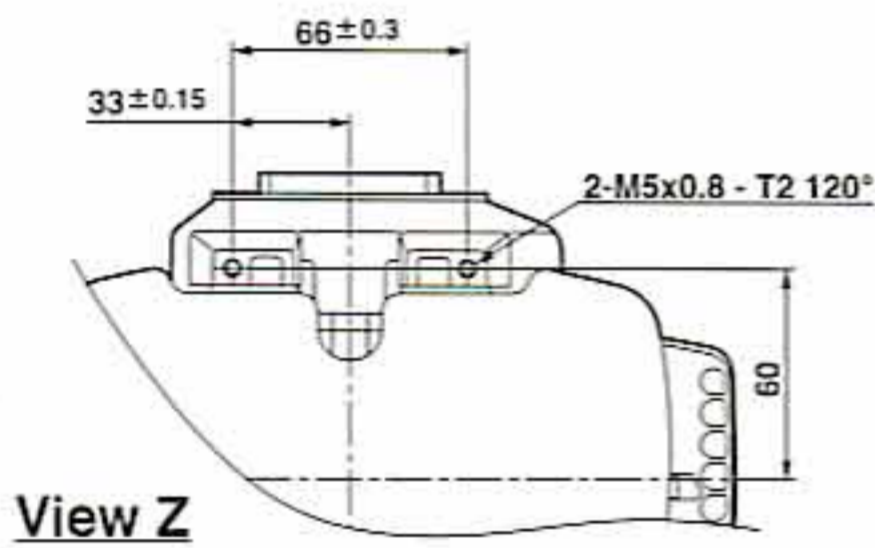
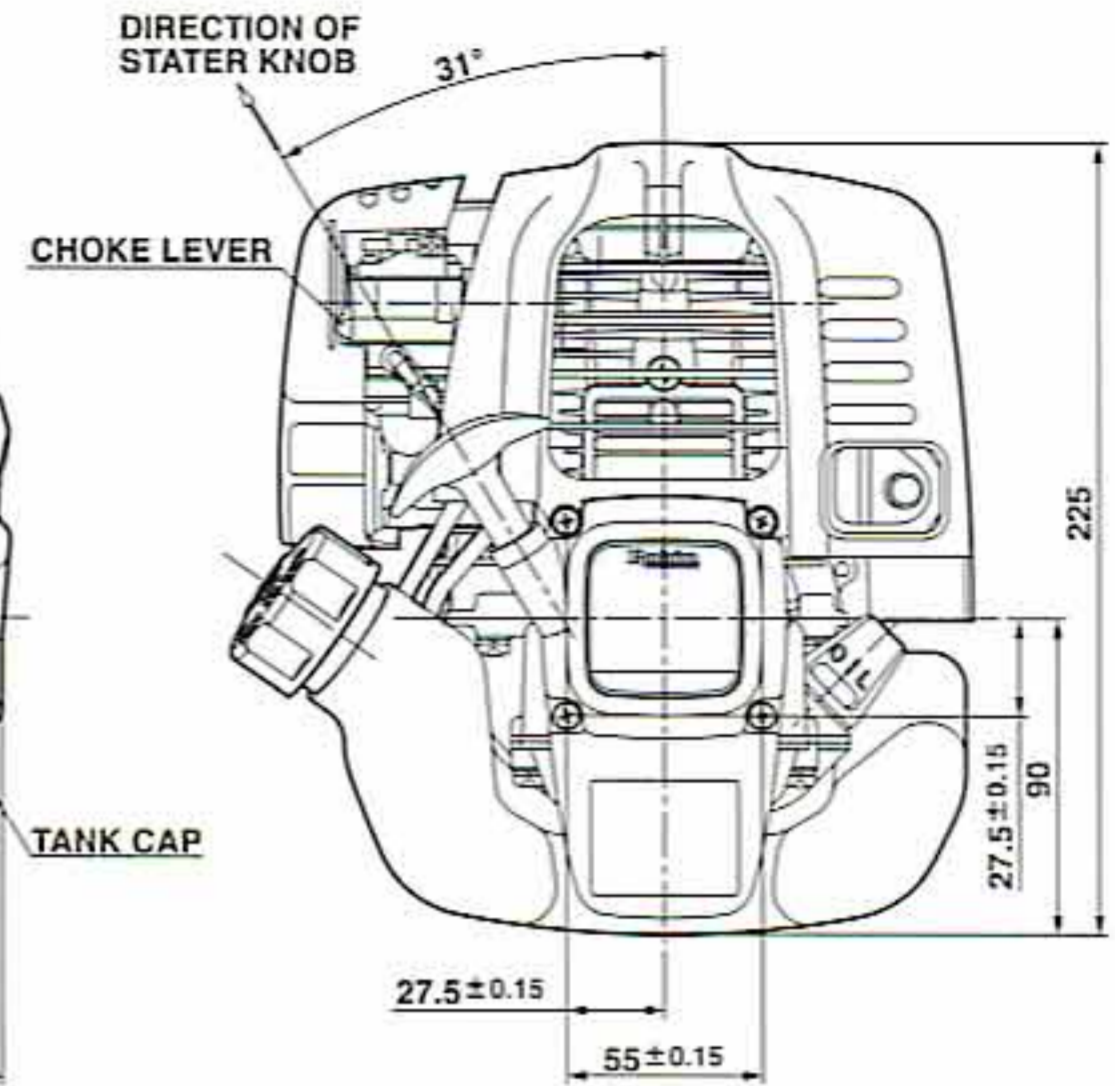
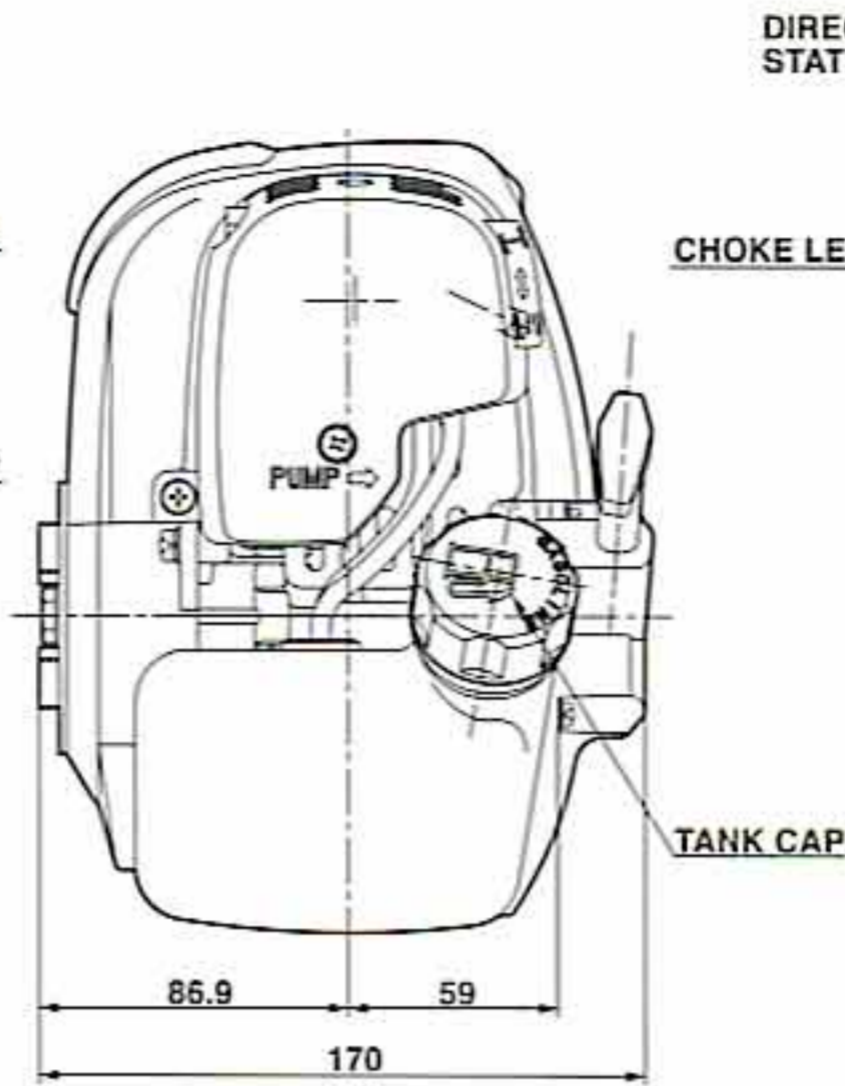
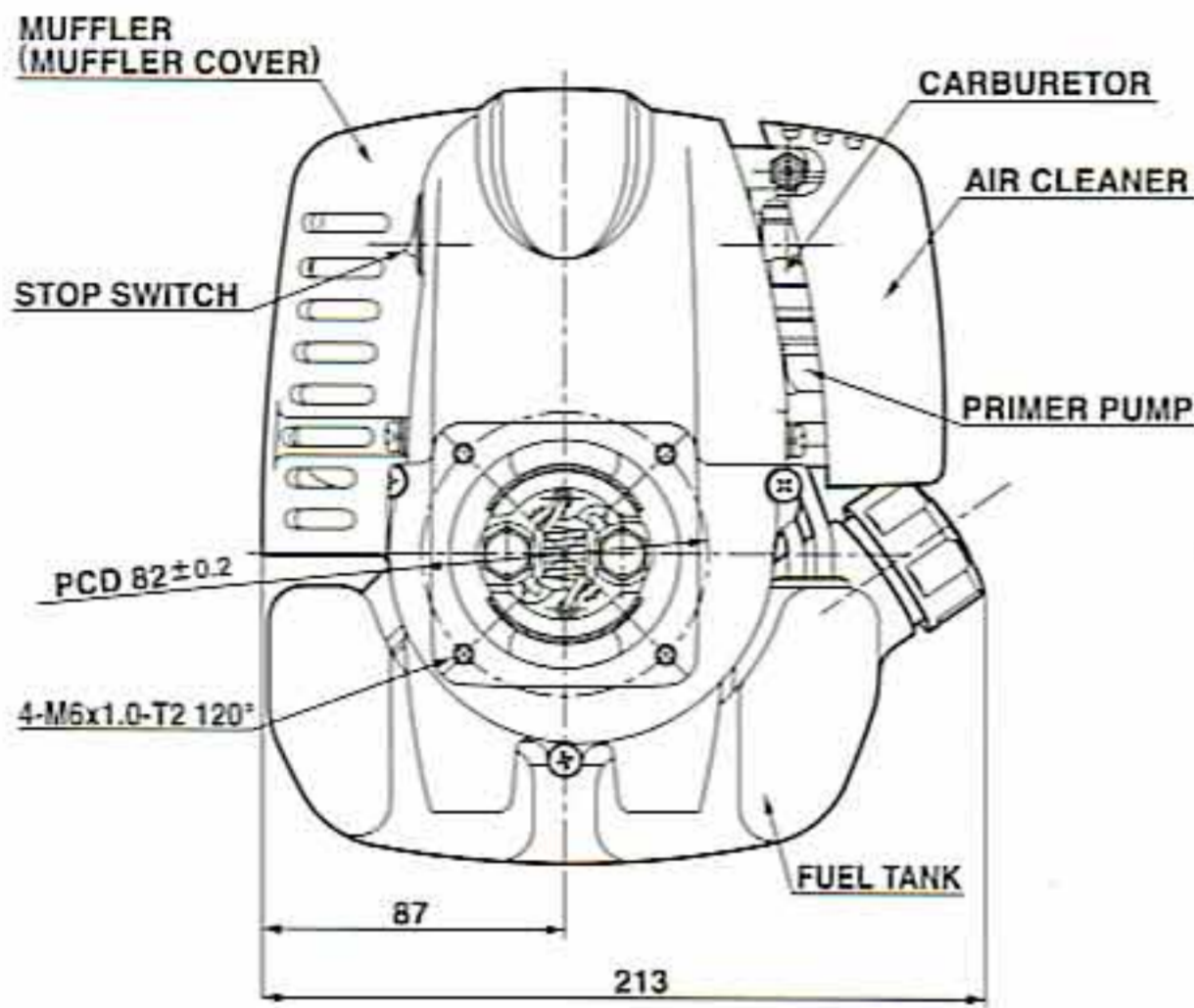

EH025A PERFORMANCE CURVES

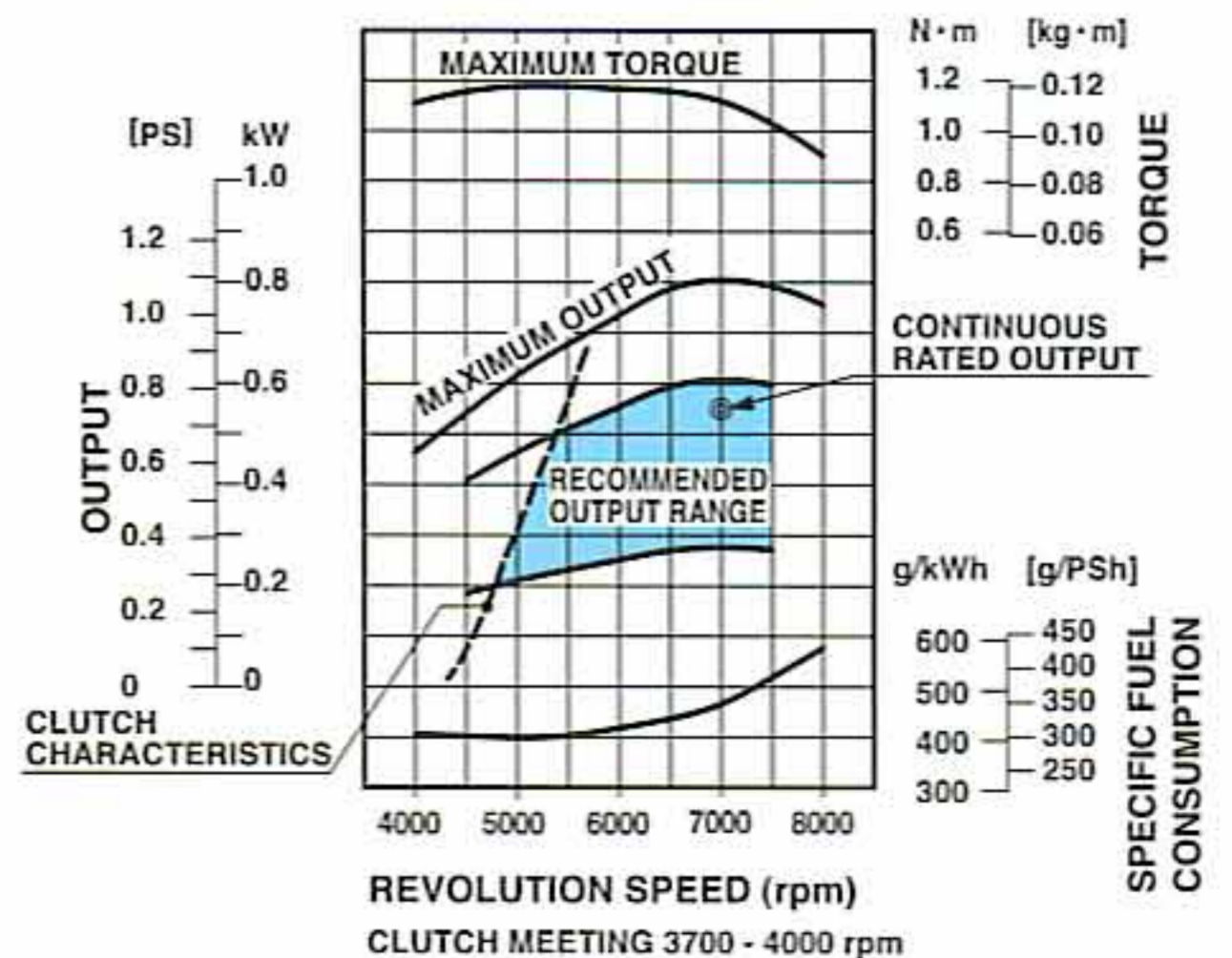

EH035

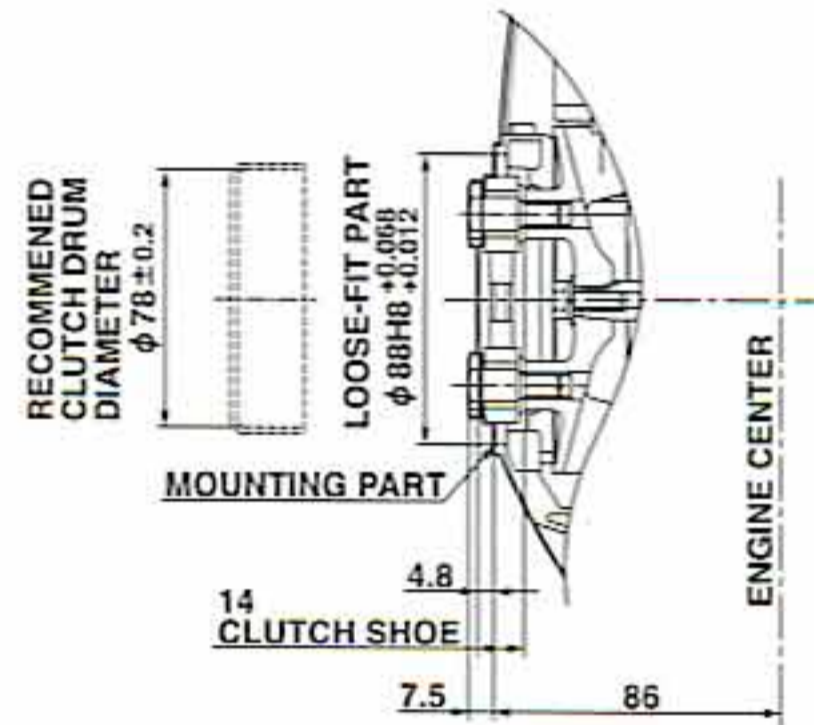
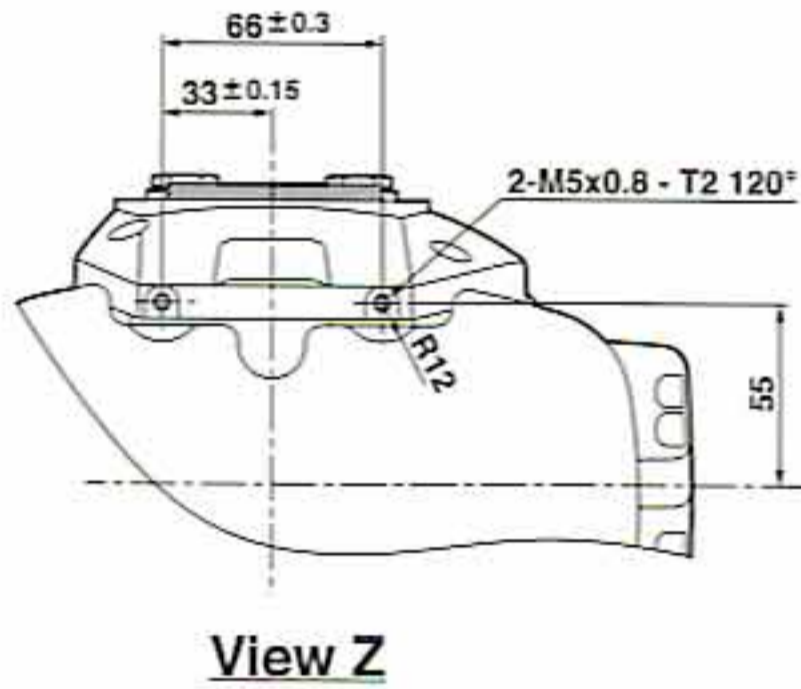
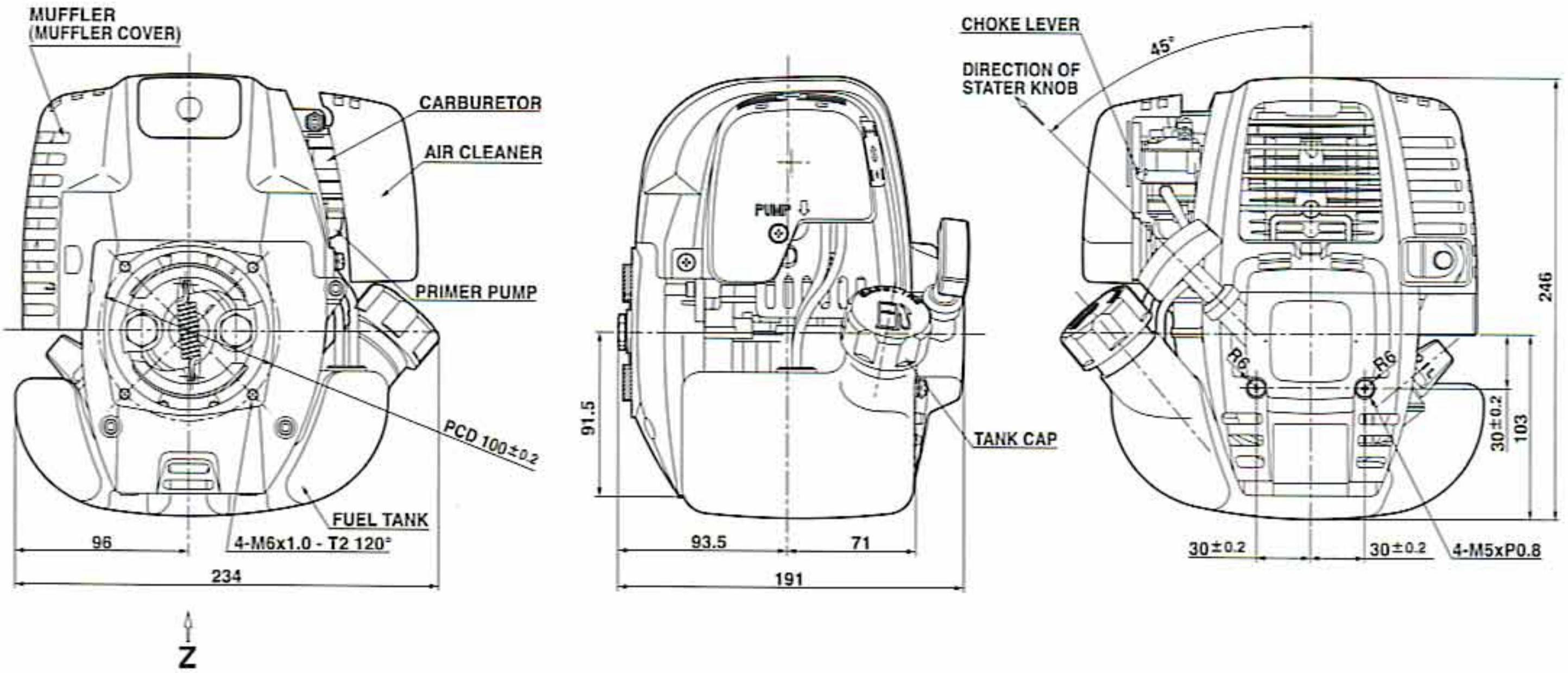

EH035A PERFORMANCE CURVES

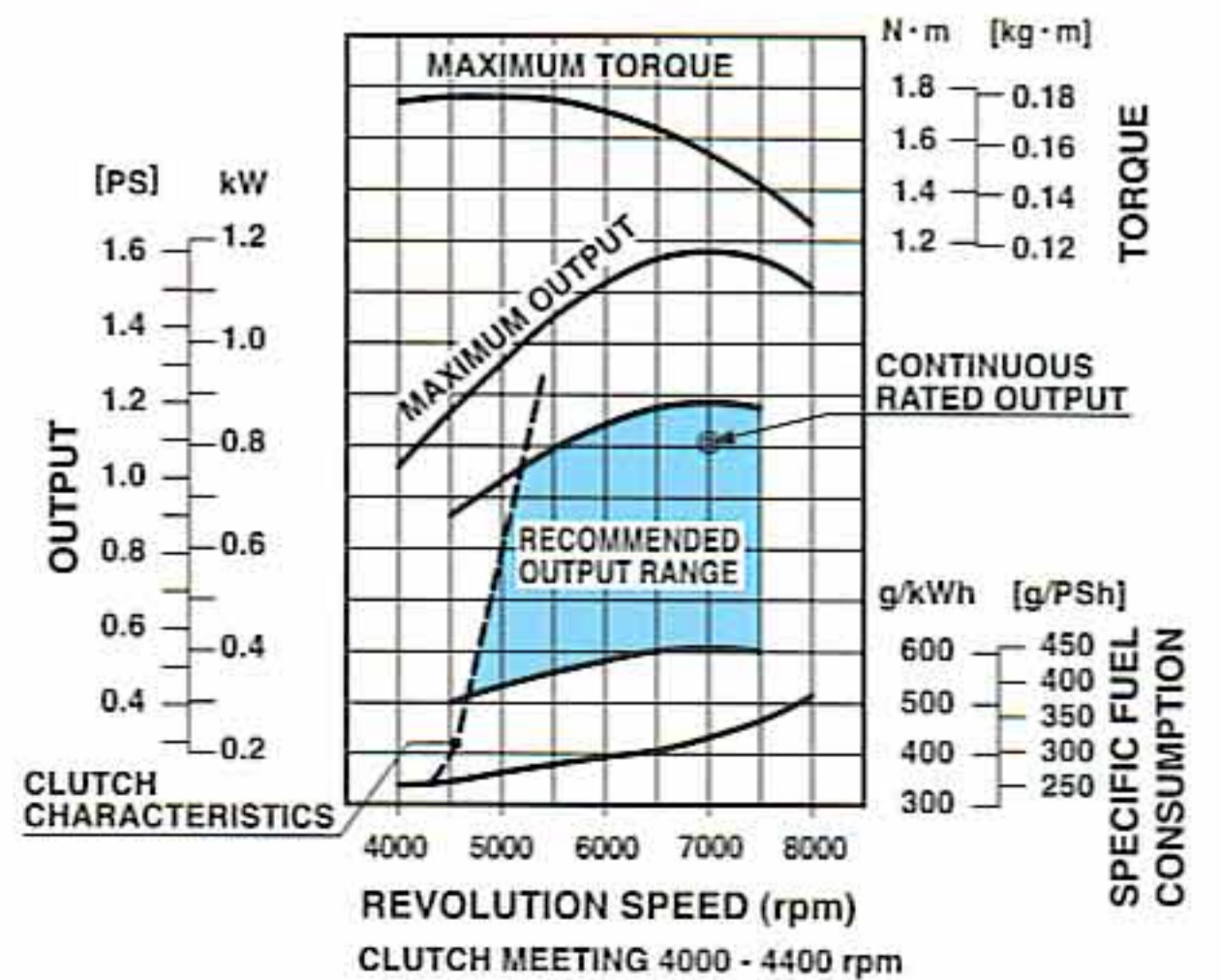

EHO35V

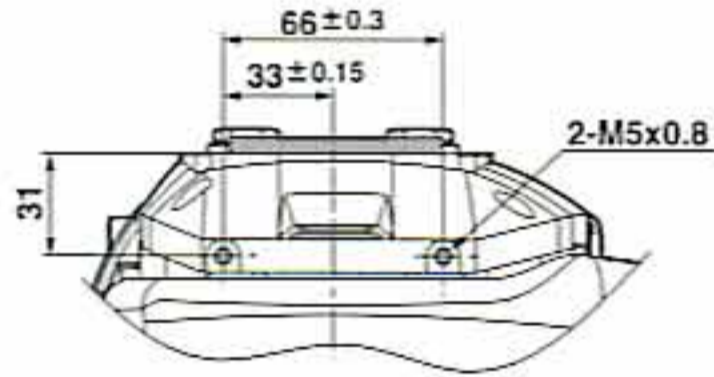
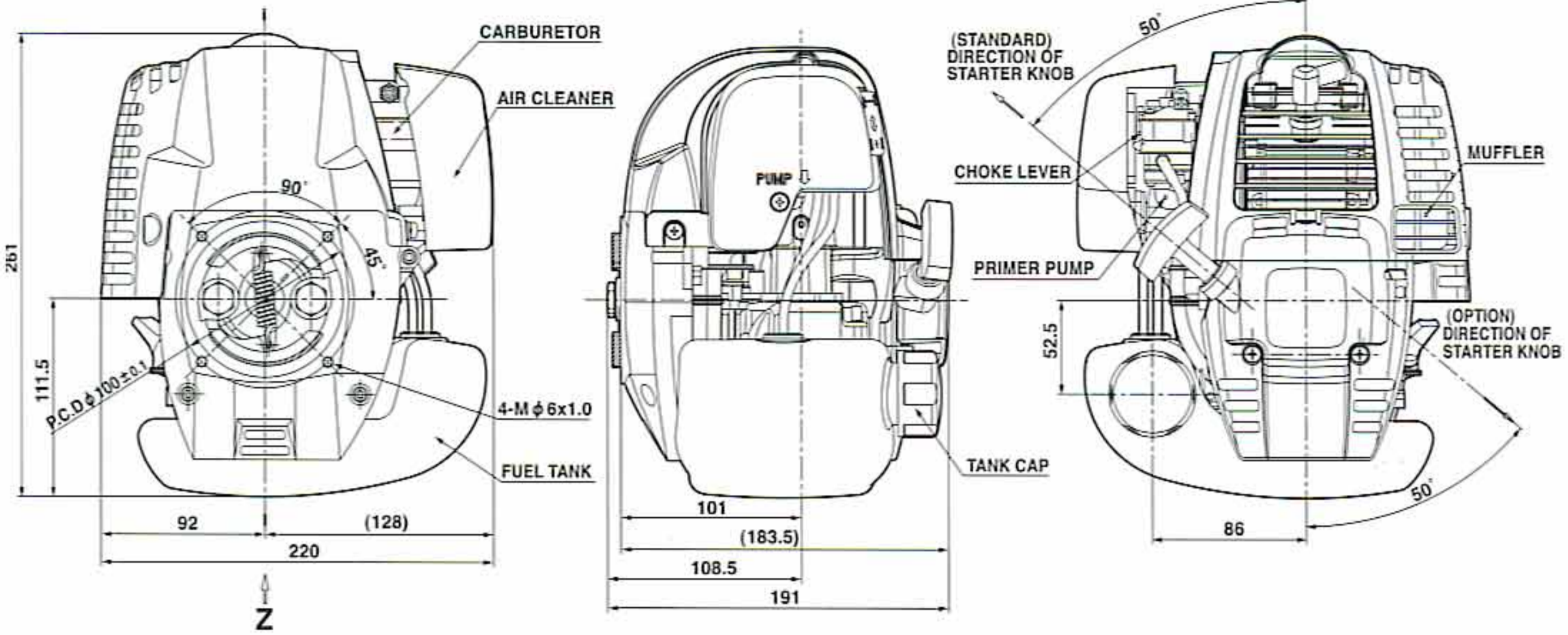

View Z

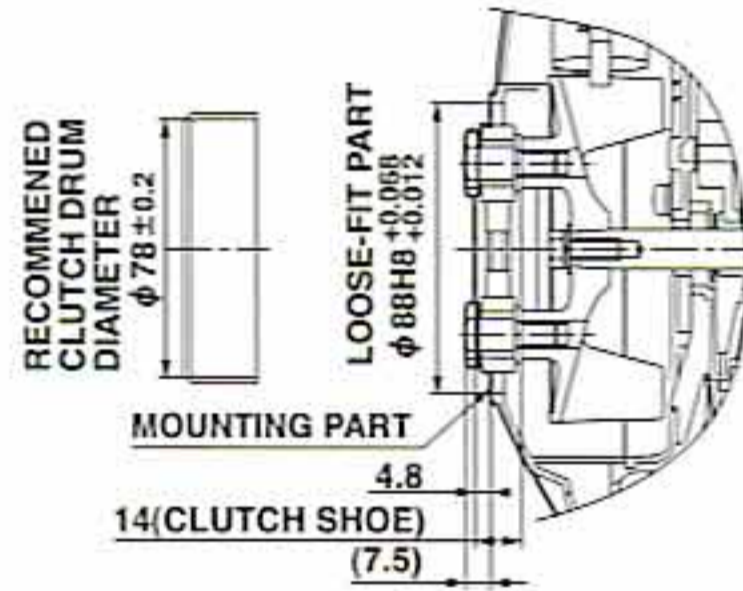

EHO35V PERFORMANCE CURVES

